

AT-2412C, AT-2412D, AT-2512C, AT-2612D, AT-2612E, AT-2812C, AT-2812D, DT-2412C, R1000, R1400, R1700, SR1400, SR1700, SR1900, SR2000, SRO2400, VVO2512AT, V2812AT, VO3112AT, VT1708, VT2009B, VT2014B, VT2214, VT2412B, VT2514B, VT-2512C, VT-2812C

Posterior Neumático Rear Pneumatic

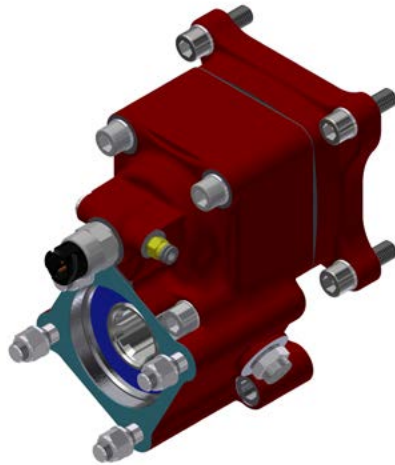

Descripción Description

Kit de toma de fuerza + brida (sin eje) toma constante, montaje en registro frontal de 4 taladros de la caja de cambios. Accionamiento neumático, salida ISO 4 taladros. Indicador de funcionamiento y eje adaptador opcional.

Base PTO + flange Kit (without shaft) constant mesh, mounting on rear 4 bolts-window of the Gearbox. Pneumatic shifting, output Iso 4 bolts. Optional: Passing contact switch and adapter shaft.

Datos Principales Main Data

Relación Interna Internal Ratio		1: 1.3	1: 1.5	1: 1.8
Par nominal Torque (Nm)	Continuo Continuous	450	400	350
	Intermitente Intermittent	630	560	490
Potencia (1000 r.p.m.) Power (1000 r.p.m.)		97 CV // 72 Kw	87 CV // 65 Kw	75 CV // 56 Kw
Lado de montaje Mounting position		Posterior Rear		
Sentido de giro de la bomba Pump rotation		Derecho ClockWise		
Peso Weight (Kg)		12		
R1000, R1400, R1700		1:0,928	1: 1,071	1:1,285
SR1400, SR1700, SR1900, VT2014B, VT2214B, VT2514B, DT-2412C	Larga High	1:1,167	1: 1,346	1:1,615
	Normal	1:0,928	1: 1,071	1:1,285
SR2000	Larga High	1:1,087	1: 1,254	1:1,505
	Normal	1:0,861	1: 0,994	1:1,193
SRO2400	Larga High	1:1,365	1: 1,575	1:1,890
	Normal	1:1,087	1: 1,254	1:1,505
VT1708, VT2009B		1:0,928	1: 1,071	1:1,285
AT-2412C/D, AT-2512C, AT-2612D/E, AT-2812C/D, V-2412AT, V-2512AT, V-2812AT, VT-2512C, VT-2812C	Larga High	1:1,197	1: 1,381	1:1,657
	Normal	1:0,928	1: 1,071	1:1,285
VO2512AT, VO3112AT	Larga High	1:1,524	1: 1,759	1:2,111
	Normal	1:1,193	1: 1,377	1:1,652
VTO2214B, VTO2514B	Larga High	1:1,450	1: 1,673	1:2,008
	Normal	1:1,167	1: 1,346	1:1,615

Códigos y Combinaciones Part Numbers and Combinations

Kit base + brida Base kit + flange	Plato Flange	Bomba Pump (DIN 5462) + Kit de eje adaptador Adapter shaft kit
Relación Interna Internal Ratio	1: 1.3	11113K02
	1: 1.5	11112K02
	1: 1.8	11111K02
		11113K03
		11112K03
		11111K03
		R1000, SR1700, ... (L=267mm)
		R1000, ... Retarder (L=302mm)
		DT-2412C, V2412 (L=229 mm)
		110104
		110304
		116504

AT-2412C, AT-2412D, AT-2512C, AT-2612D, AT-2612E, AT-2812C, AT-2812D, DT-2412C, R1000, R1400, R1700, SR1400, SR1700, SR1900, SR2000, SRO2400, VVO2512AT, V2812AT, VO3112AT, VT1708, VT2009B, VT2014B, VT2214, VT2412B, VT2514B, VT-2512C, VT-2812C

Posterior Neumático Rear Pneumatic

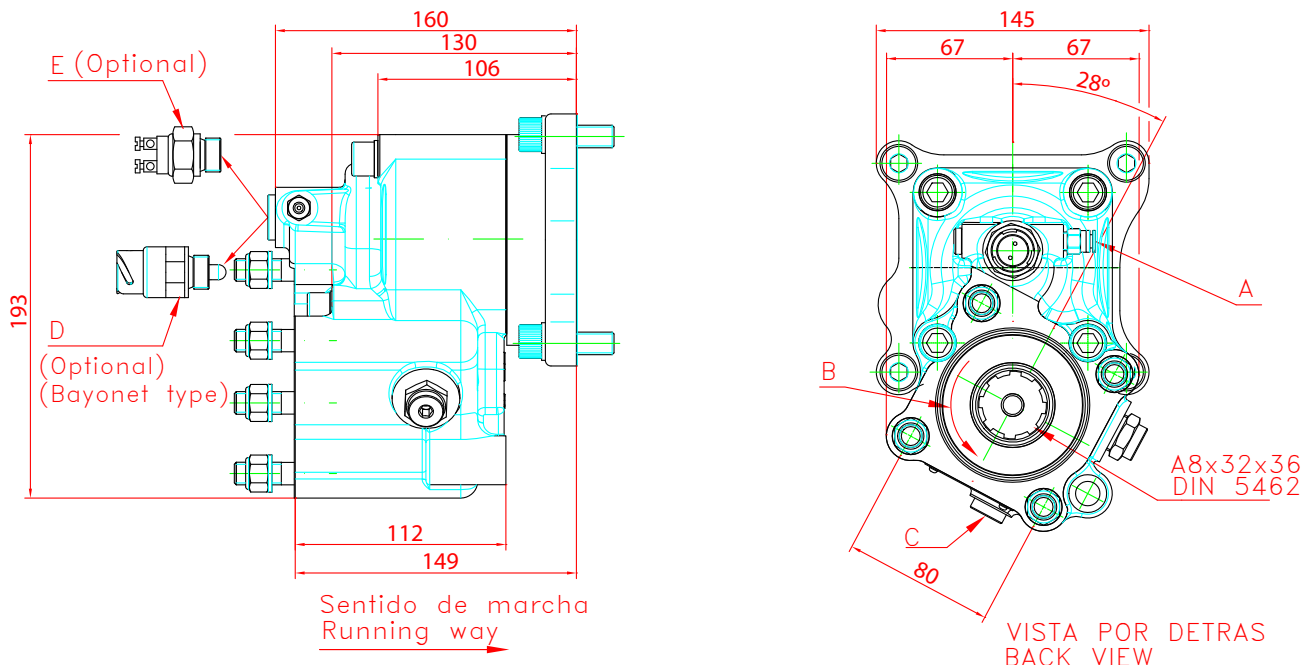

Notas		Notes	
A	Toma de aire, rosca 1/8" GAS	A	Air connection, thread 1/8" BSP
B	Sentido de giro	B	Rotation
C	Tapón de drenaje del aceite	C	Oil drain plug
D	Interruptor de contacto.(9024999)	D	Passing contact switch. P/N 9024999
E	Interruptor neumático (100070018)	E	Pressure switch. P/N 100070018

Tipos de Salida Output Types

Adaptador Plato / Flange Adapter

SAE: 1100
1300
1400

DIN: 90
100

